

Enquiry form

Contact name _____

Company _____

Postal address _____

Phone number _____ Fax number _____

We are in the market for a new crane / crane component

We only require a budget price at this stage

Crane information

Safe working load (tonne): _____ c. Top of rail to building inside knee (mm): _____

Length of travel (mm): _____ d. Roof angle (if known): _____

Height of lift (mm): _____ e. Clearance - rail/wall (mm): _____

a. Floor to top of rail (mm): _____ f. Rail size (for existing buildings): _____

b. Span rail center to rail center (mm): _____

Application: (software is available to calculate crane duty - M rating)

Light duty (maintenance, light stores, light workshop)

Medium duty (medium and general duty workshop and stores)

Heavy duty (process, steel merchant, magnet or ladel crane)

Special Application (unique process, environment)

Crane type

Single girder

Double girder

Goliath / semi-goliath

Jib crane

Crane Control

Roving pendant

Pendant fixed from hoist

Radio control

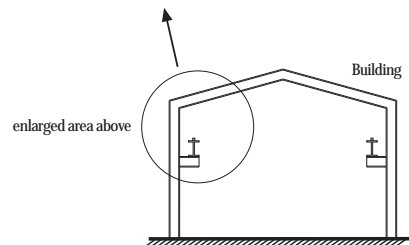
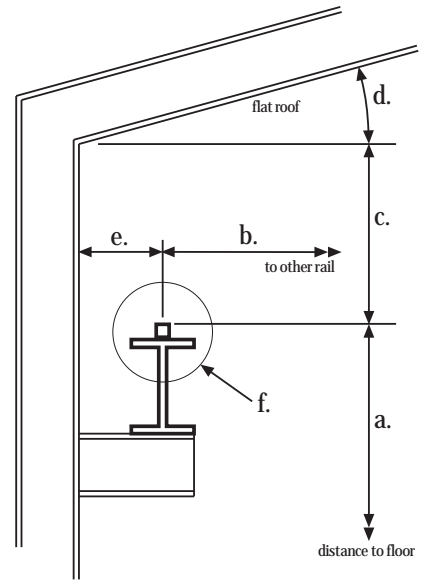

Two speed travel - standard hoist 5/1.25 m/min cross travel 20/5 m/min long travel 32/8 m/min
 alternative _____ / _____ m/min _____ / _____ m/min _____ / _____ m/min

Additional information: (please attach building portal drawing or sketch if available)